



DT3K*
EXPLOSION-PROOF
SOLENOID ACTUATED
POPPET VALVE
ATEX, IECEx, PESO
SERIES 10

SUBPLATE MOUNTING
ISO 4401-03

p max 350 bar
Q max 25 l/min

OPERATING PRINCIPLE

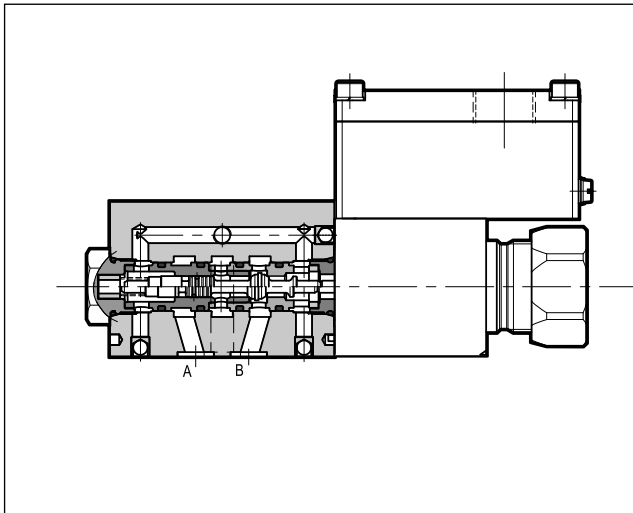

- Directional solenoid actuated poppet valve, direct operated, with ISO 4401-03 mounting surface.
- Three-port version, normally open or normally closed. These valves apply in hydraulic circuits applications where leakage free is strictly required.
- They are compliant with ATEX, IECEx or PESO requirements and are suitable for use in potentially explosive atmospheres, for surface plants or mines.
- The DT3K* valves are supplied with a zinc-nickel finishing surface treatment that ensures a salt spray resistance up to 600 h.
- **Details for classification, operating temperatures and electrical characteristics are in the technical data sheet 02 500 'Explosion proof classification'.**

PERFORMANCES

(obtained with mineral oil with viscosity of 36 cSt at 50°C)

Maximum operating pressure: P - A - B ports T port	bar	350 210
Maximum flow	l/min	25
Operating temperatures (ambient and fluid)	°C	see data sheet 02 500
Fluid viscosity range	cSt	10 ÷ 400
Fluid contamination degree		according to ISO 4406:1999 class 20/18/15
Recommended viscosity	cSt	25
Mass	kg	2.3

HYDRAULIC SYMBOLS

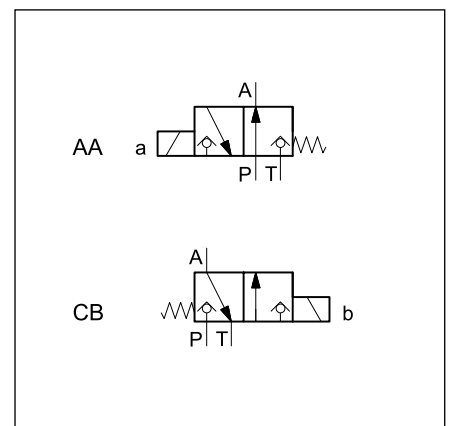

1 - IDENTIFICATION CODE

	D	T	3		-	3		/		/	10		-		K9		/	CB	
--	----------	----------	----------	--	----------	----------	--	----------	--	----------	-----------	--	----------	--	-----------	--	----------	-----------	--

Solenoid actuated poppet valve

Size: ISO 4401-03

Explosion-proof certification: **See table 1.1**

3-ports version

Types of configuration:
AA = P→A in the rest position, solenoid on side A
CB = A→T in the rest position, solenoid on side B

Variant on line P (omit if not required):
D15 = orifice Ø1.5

Series No.
 (The overall and mounting dimensions remain unchanged from 10 to 19)

Seals:
 For temperature range -20 / +80 °C
N = NBR seals for mineral oil (**standard**)
V = FPM seals for special fluids

Option: **/T5** version in T5 temperature class. Omit if not required.

Blind ring nut (see p. 6)

Connection type for cable gland upper connection:
T01 = M20x1.5 - ISO 261
T02 = Gk 1/2 - UNI EN 10226-2
T03 = 1/2" NPT - ANSI B1.20.1 (ex ANSI B2.1)
 side connection:
S01 = M20x1.5 - ISO 261
S02 = Gk 1/2 - UNI EN 10226-2
S03 = 1/2" NPT - ANSI B1.20.1 (ex ANSI B2.1)
S04 = M16x1.5 - ISO 261

Coil electrical connection: junction box

Power supply
 Direct current (DC)
D12 = 12 V
D24 = 24 V
D48 = 48 V
D110 = 110 V
 Alternate current with built-in rectifier bridge (RAC)
R120 = 120 V
R240 = 240 V

NOTE: Valves are supplied with zinc-nickel surface treatment, that is suitable to ensure a salt spray resistance up to 600 h (test operated according to UNI EN ISO 9227 standards and test evaluation operated according to UNI EN ISO 10289 standards).

Version with monobloc steel coil
 Standard coils are made of zinc-nickel steel, with anodized aluminium junction box on it.
 Monobloc coils **MD24K9S01** completely made of steel are available upon request. They have zinc-nickel treatment, power supply voltage D24 and cable gland connection type S01. Other variants for voltage and cable gland connection are available, always on request.

1.1 - Names of valves per certification

	ATEX		IECEX		PESO	
for gases for dusts	KD2	II 2GD	KXD2	IECEX Gb IECEX Db	KPD2	PESO Gb not applicable for dust
for mines	KDM2	I M2	KXDM2	IECEX Mb	not applicable for mines	

NOTE: Refer to the technical data sheet 02 500 for marking, operating temperatures and available versions.

2 - CHARACTERISTIC CURVES

(values obtained with viscosity 36 cSt at 50 °C, with DC solenoid valves)

2.1 - Pressure drops

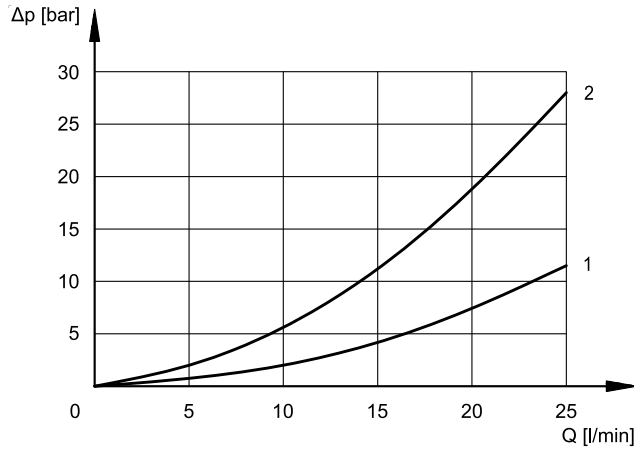

CURVE	
P→A	A→T
1	2

2.2 - Performance limits

The curves define the flow rate operating fields according to the valve pressure of the different versions. The values have been obtained according to ISO 6403 norm with solenoids at rated temperature and supplied with voltage equal to 90% of the nominal voltage, with mineral oil with viscosity 36 cSt, temperature 50 °C and filtration according to ISO 4406:1999 class 18/16/13.

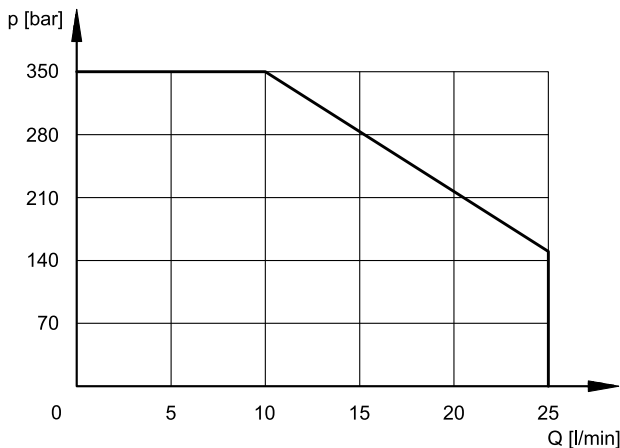

2.3 - Switching times

The indicated values are obtained according to ISO 6403 standard, with mineral oil viscosity 36 cSt at 50°C.

TIMES (± 10%) [ms]	ENERGIZING	DE-ENERGIZING
DC	250	130

3 - FLOW LIMITATION

In applications where the poppet valve is fed by an accumulator or by high delivery pumps it is necessary to limit the flowrate within the valve working limits by means of orifices. The orifice must be located on accumulator side always.



WARNING! During transition from initial position to end position all the valve ports are connected. This means that as long as the switching is not completed, the oil will flow from the P and A lines to the tank.

4 - ELECTRICAL CHARACTERISTICS

(values $\pm 5\%$)

Coil type	Nominal voltage [V]	Resistance at 20°C [Ω]	Current consumpt. [A]	Power consumpt. [W]
D12	12	7.2	1.7	20
D24	24	28.7	0.83	20
D48	48	115	0.42	20
D110	110	549	0.2	22

VOLTAGE SUPPLY FLUCTUATION (ripple included)	$\pm 10\% V_{nom}$
DUTY CYCLE	100%
ELECTROMAGNETIC COMPATIBILITY (EMC)	According to 2014/30/EU
CLASS OF PROTECTION Atmospheric agents Coil insulation (VDE 0580)	IP66/IP68 class H

Coil type (NOTE)	Nominal voltage [V]	Freq. [Hz]	Resistance at 20°C [Ω]	Current consumpt. [A]	Power consumpt. [VA]
R120	110V-50Hz 120V-60Hz	50/60	489.6	0.19	21
				0.21	25
R240	230V-50Hz 240V-60Hz	50/60	2067.7	0.098	22,5
				0.1	24

NOTE: type R* coils are for alternating current supply for both 50 or 60 Hz. For R* coils the resistance can not be measured in the usual way because of the presence of diodes bridge inside the coil.

4.1 - Wiring

In order to realise the electrical connection of the coil, it is necessary to access the terminal block (1) unscrewing the 4 screws (2) that fasten the cover (3) with the box (4) that contains the terminal block.

The electrical connection is polarity-independent.

By doing electrical connection it is important to connect also the grounding point (5) in the terminal block box (M4 screws), through suitable conductors with the general grounding line of the system.

On the external body of the coil there is a grounding point (6) (M4 screw) that allow to ensure equipotentiality between the valve and the general grounding line of the system; connecting this point the regulation of the EN 13463-1 standard, that impose to verify the equipotentiality of the elements included in a potentially explosive environment (the maximum resistance between the elements must be 100 Ω), is guaranteed.

At the end of the electrical wiring, it is necessary to reassemble the cover (3) on the box (4), checking the correct positioning of the seal located in the cover seat and fastening the 4 M5 screws with a torque of 4.9÷6 Nm.

Electrical wiring must be done following in compliance with standards about protection against explosion hazards.

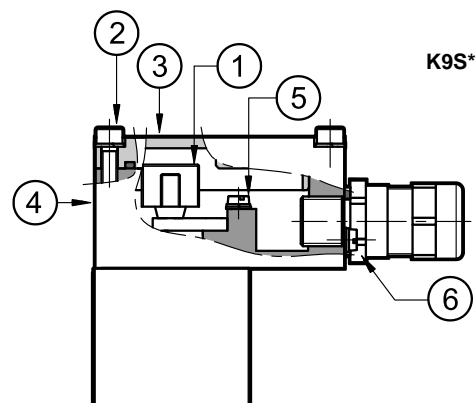
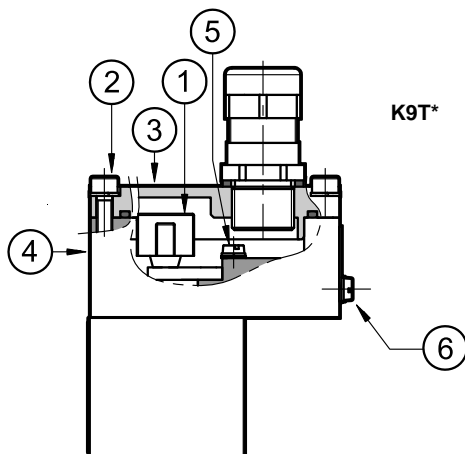

Characteristics of the cables connectable for wiring are indicated in the table below:

Function	Cable section
Operating voltage cables connection	max 2.5 mm ²
Connection for internal grounding point	max 2.5 mm ²
Connection for external equipotential grounding point	max 6 mm ²

Cables for wiring must be non-armoured cables, with external covering sheath and must be suitable for use in environments with temperatures from - 20 °C to +110 °C (for valves either with N or V seals).

Cable glands (which must be ordered separately, see point 8) allow to use cables with external diameter between 8 and 10 mm.

4.2 - Electrical diagrams

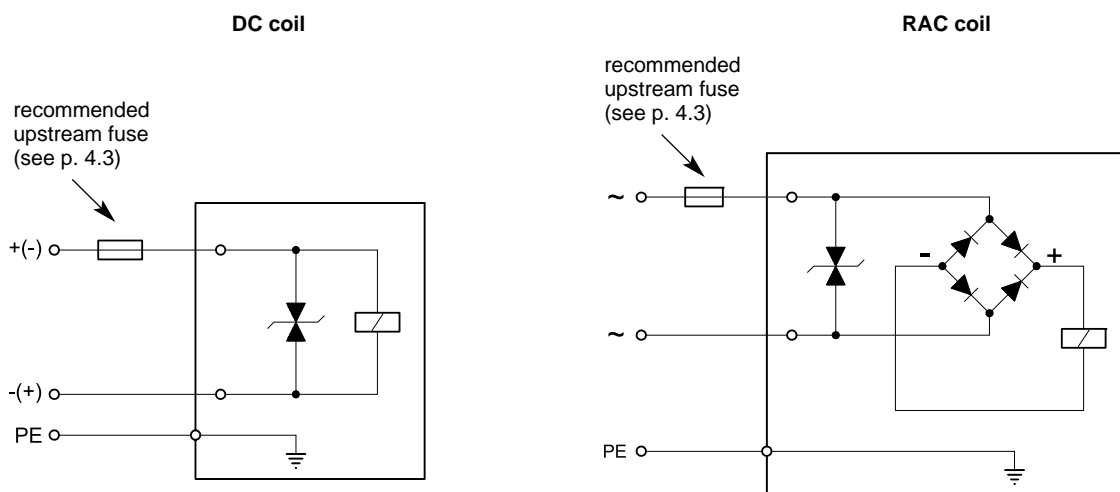

4.3 - Overcurrent fuse and switch-off voltage peak

Upstream of each valve, an appropriate fuse (max 3 x I_n according to IEC 60127) or a protective motor switch with short-circuit and thermal instantaneous tripping, as short-circuit protection, must be connected. The cut-off power of the fuse must correspond or exceed the short circuit current of the supply source. The breaking capacity of the fuse link shall be the same as or higher than the maximum short-circuit current expected to occur at the place of installation (normally 1500 A).

The fuse or the protective motor must be placed outside the dangerous area or they must be protected with an explosion-proof covering.

In order to safeguard the electronic device to which the valve is connected, there is a protection circuit in the coil, that reduces voltage peaks, which can occur when inductances are switched off.

The table shows the type of fuse recommended according to the nominal voltage of the valve and to the value of the voltage peaks reduction.

Coil type	Nominal voltage [V]	Rated current [A]	Recommended pre-fuse characteristics medium time-lag according to DIN 41571 [A]	Maximum voltage value upon switch off [V]	Suppressor circuit
D12	12	1.7	2.5	- 49	Transient voltage suppressor bidirectional
D24	24	0.83	1.25	- 49	
D48	48	0.42	0.6	- 81	
D110	110	0.2	0.3	- 309	
R120	120	0.21	0.3	- 3	
R240	240	0.1	0.15	- 3	

5 - OVERALL AND MOUNTING DIMENSIONS

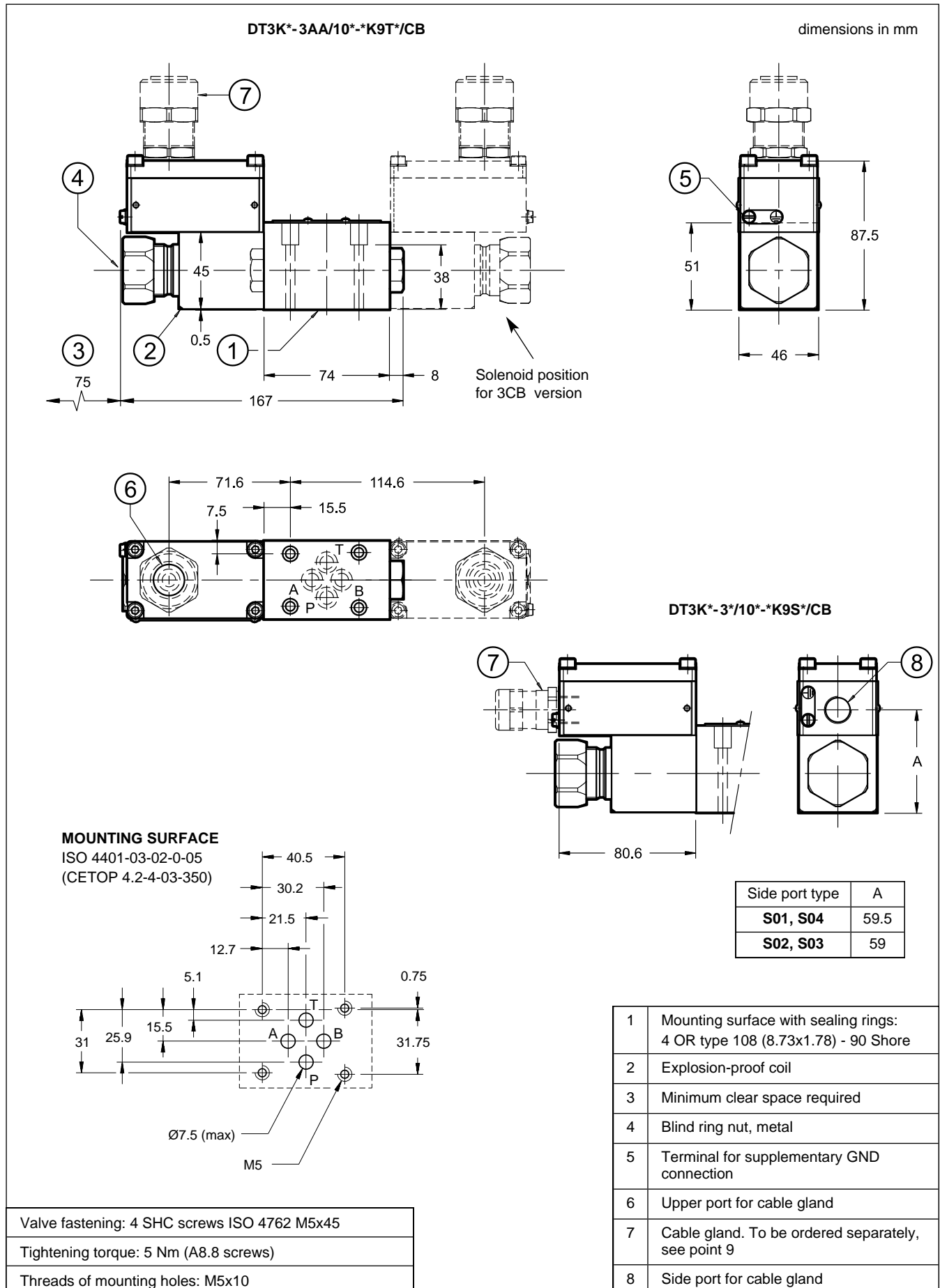

6 - CB - BLIND RING NUT

The metal ring nut protects the solenoid tube from atmospheric agents and isolates the manual override from accidental operations. The ring nut is tightened on a threaded fastener that keeps the coil in its position even without the ring nut.

To access the manual override, loosen the ring nut and remove it; then reassemble hand tightening, until the ring stops.

Activate the manual override always and only with non-sparking tools suitable for use in potentially explosive atmospheres.

More information on safe use of explosion-proof components are provided in the instruction manual, always supplied with the valve.

7 - HYDRAULIC FLUIDS

Use mineral oil-based hydraulic fluids HL or HM type, according to ISO 6743-4. For these fluids, use NBR seals (code N). For fluids HFDR type (phosphate esters) use FPM seals (code V). For the use of other fluid types such as HFA, HFB, HFC, please consult our technical department.

Using fluids at temperatures higher than 80 °C causes a faster degradation of the fluid and of the seals characteristics. The fluid must be preserved in its physical and chemical characteristics.

8 - INSTALLATION



Installation must adhere to instructions reported in the *Use and Maintenance manual*, always attached to the valve. Unauthorized interventions can be harmful to people and goods because of the explosion hazards present in potentially explosive atmospheres.

Valves can be mounted in any position. Valve fastening takes place by means of screws or tie rods, laying the valve on a lapped surface, with values of planarity and smoothness that are equal to or better than those indicated in the drawing.

If the minimum values of planarity or smoothness are not met, fluid leakages between valve and mounting surface can easily occur.

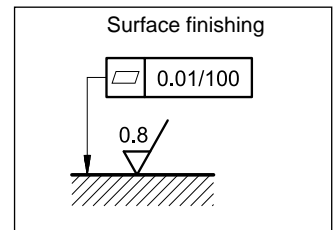

9 - CABLE GLANDS

Cable glands must be ordered separately; Duplomatic offers some types of cable glands with the following features:

- version for non-armoured cable, external seal on the cable (suitable for $\varnothing 8 \div 10$ mm cables);
- ATEX II 2GD, I M2; IECEx Gb, Db, Mb;
- cable gland material: nickel brass
- internal rubber tip material: silicone
- ambient temperature range: $-65 \text{ }^{\circ}\text{C} \div +220 \text{ }^{\circ}\text{C}$
- protection degree: IP66/IP68

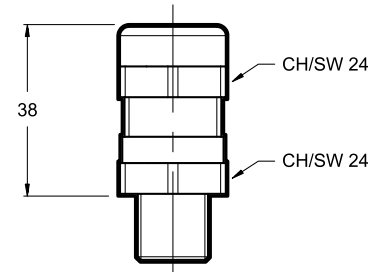

To order the desired cable glands, specify description, code and quantity.

Description: CGK2/NB-01/10

Code: 3908108001

M20x1.5 - ISO 261 male thread, suitable for coils with T01 and S01 connections. It is supplied equipped with copper washer, that must be assembled between the cable gland and the coil, so as to ensure IP66/IP68 protection degree.

Tightening torque: 45 \div 50 Nm

Description: CGK2/NB-02/10

Code: 3908108002

Gk 1/2 - UNI EN 10226-2 male thread, suitable for coils with T02 and S02 connections. The customer must apply LOCTITE® 243™ threadlocker or similar between the cable gland connection thread and the coil in order to ensure IP66/IP68 protection degree.

Tightening torque: 20 \div 25 Nm

Description: CGK2/NB-03/10

Code: 3908108003

1/2" NPT - ANSI B1.20.1 (ex ANSI B2.1), suitable for coils with T03 and S03 connections. The customer must apply LOCTITE® 243™ threadlocker or similar between the cable gland connection thread and the coil in order to ensure IP66/IP68 protection degree.

Tightening torque: 20 \div 25 Nm

Description: CGK2/NB-04/10

Code: 3908108004

M16x1.5 - ISO 261 male thread, suitable for coils with S04 connection. It is supplied equipped with copper washer, that must be assembled between the cable gland and the coil, so as to ensure IP66/IP68 protection degree.

Tightening torque: 45 \div 50 Nm



10 - SUBPLATES

(see catalogue 51 000)

Type with rear ports	PMMD-AI3G
Type with side ports	PMMD-AL3G
P, T, A, B ports dimensions X, Y ports dimensions	3/8" BSP -

NOTE: Subplates (to be ordered separately) contain neither aluminium nor magnesium at a rate higher than the value allowed by norms according to ATEX directive for category II 2GD and I M2.

The user will bear to do the complete assessment of the ignition risk that can occur from the relative use in potentially explosive environments.

EXPLOSION-PROOF CLASSIFICATION

for

SOLENOID AND PROPORTIONAL VALVES

ref. catalogues:

pressure control valves

RQM*K*-P	21 515
P*E*K*	81 316
ZDE3K*	81 515
DZCE*K*	81 606

flow control valves

QDE3K*	82 225
---------------	---------------

directional valves

D*K*	41 515
DT3K*	42 215
DS(P)E*K*	83 510

GENERAL INFO

This informative technical datasheet displays information about **classification and marking** of Duplomatic explosion-proof valves range.

Duplomatic MS offers valves with the following certifications:

ATEX	II 2G	II 2D	I M2
IECEX	Gb	Db	Mb
PESO	Gb		

Instructions for use and maintenance can be found in the related manuals, always supplied together with valves.



1 - ATEX CLASSIFICATION AND TEMPERATURES

Diplomatic certificates the combination valve-coil for the valves suitable for application and installation in potentially explosive atmospheres, according to ATEX directive; the supply always includes the declaration of conformity to the directive and the operating and maintenance manual, that contains all the information needed for a correct use of the valve in potentially explosive environments.

Coils assembled on these valves have been separately certified according to ATEX directive and so they are suitable for use in potentially explosive atmospheres.

1.1 - ATEX classification for valves

Type examination certificate: AR18ATEX055

The valves are suitable for applications and installations in potentially explosive atmospheres that fall within:

ATEX II 2G ATEX II 2D	*KD2	equipment intended for use in areas in which explosive atmospheres caused by gases, vapours, mists or air/dust mixtures are likely to occur occasionally. The means of protection relating to equipment in this category ensure the requisite level of protection, even in the event of frequently occurring disturbances or equipment faults which normally have to be taken into account.
ATEX I M2	*KDM2	equipment intended for use in underground parts of mines as well as those parts of surface installations of such mines likely to be endangered by firedamp and/or combustible dust. This equipment is intended to be de-energised in the event of an explosive atmosphere.

1.2 - ATEX marking for valves

valve code		N and V seals	NL seals
*KD2	for gas	⊕ II 2G IIC T4 Gb (-20°C Ta +80°C)	⊕ II 2G IIC T4 Gb (-40°C Ta +80°C)
	for dusts	⊕ II 2D IIIC T154°C Db IP66/IP68 (-20°C Ta +80°C)	⊕ II 2D IIIC T154°C Db IP66/IP68 (-40°C Ta +80°C)
*KD2 /T5	for gas	⊕ II 2G IIC T5 Gb (-20°C Ta +55°C)	⊕ II 2G IIC T5 Gb (-40°C Ta +55°C)
	for dusts	⊕ II 2D IIIC T129°C Db IP66/IP68 (-20°C Ta +55°C)	⊕ II 2D IIIC T129°C Db IP66/IP68 (-40°C Ta +55°C)
*KDM2	mining	⊕ I M2 I T150°C Mb IP66/68 (-20°C Ta +75°C)	⊕ I M2 I T150°C Mb IP66/68 (-40°C Ta +75°C)

Specific marking as ATEX 2014/34/EU directive and related technical specifications

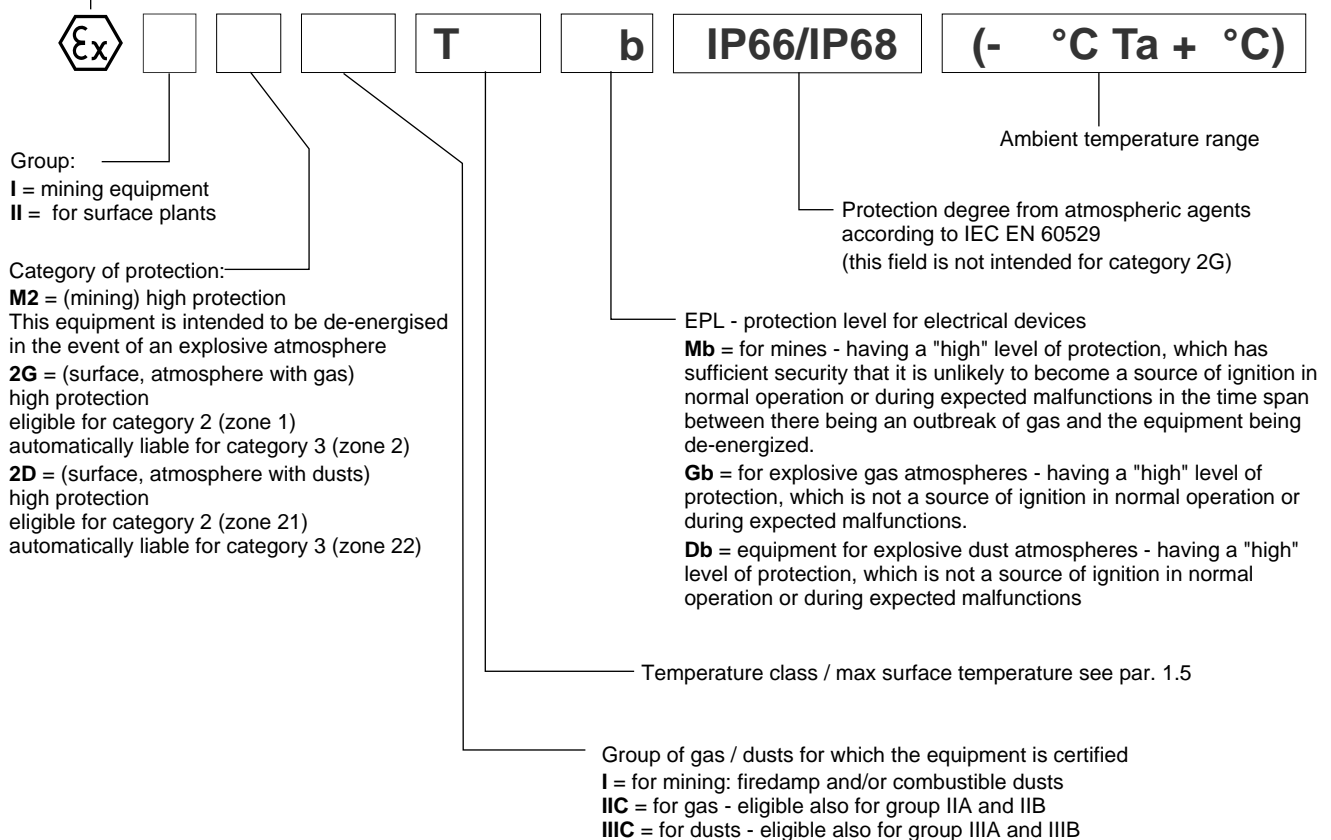







1.3 - ATEX classification of the coils

The coil of the explosion-proof valves is ATEX certified itself and, as such, is identified with its own tag, carries the relative ATEX marking. The mechanical construction of the coil housing is made in order to ensure its resistance to possible internal explosion and to avoid any explosion propagation to the outside environment, matching an "Ex db" type protection (explosion-proof coil).

Moreover, the solenoid is designed to maintain its surface temperature below the limits specified to the relevant class.

1.4 - ATEX marking on coils

for valve type *KD2	for gas for dusts	 II 2G Ex db IIC T4 Gb (-40°C Ta +80°C)  II 2D Ex tb IIIC T154°C Db IP66/IP68 (-40°C Ta +80°C)
for valve type *KD2 /T5	for gas for dusts	 II 2G Ex db IIC T5 Gb (-40°C Ta +55°C)  II 2D Ex tb IIIC T129°C Db IP66/IP68 (-40°C Ta +55°C)
for valve type *KDM2	mining	 I M2 Ex db I T150°C Mb IP66/IP68 (-40°C Ta +75°C)

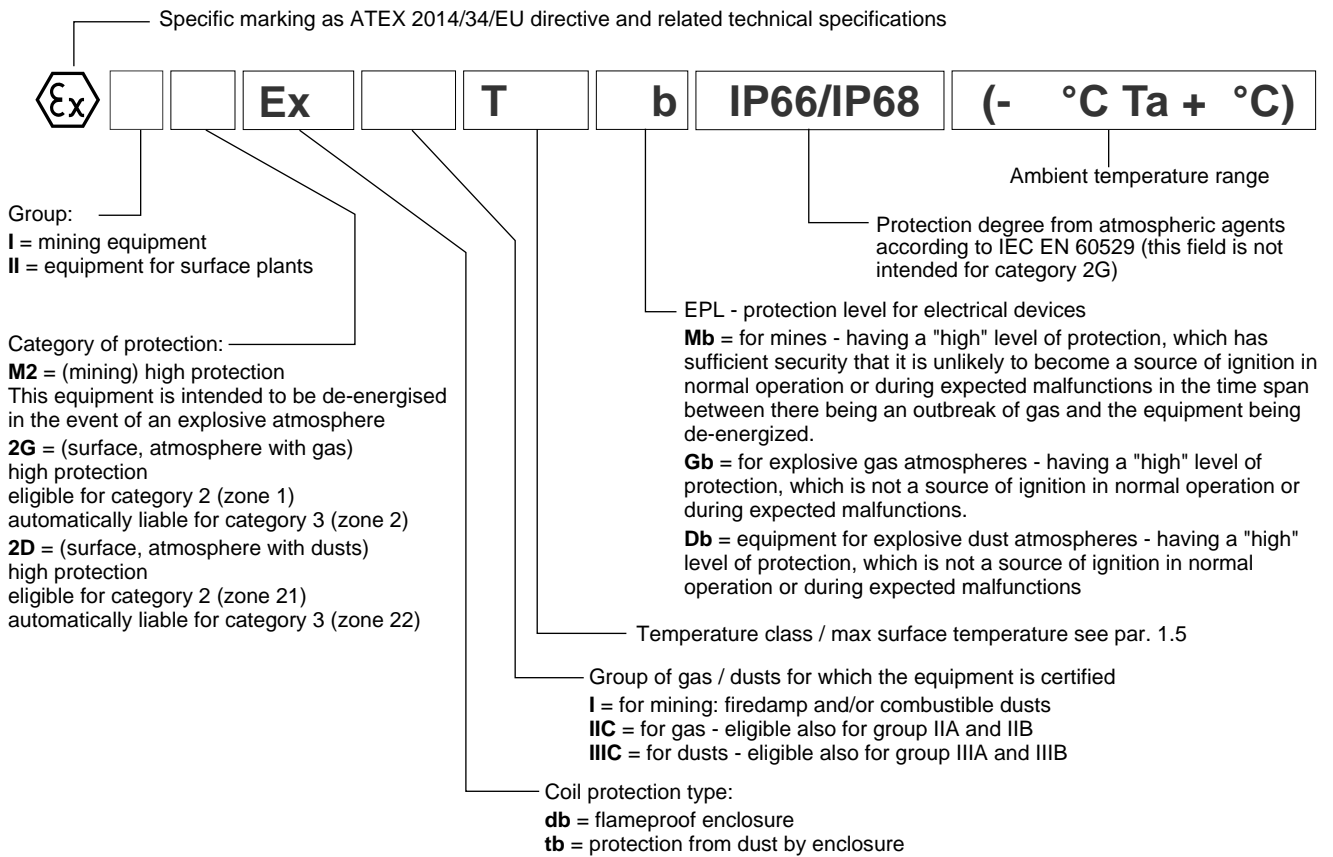

1.5 - Operating temperatures

These valves are classified according to their maximum surface temperature (EN 13463-1), which must be lower than the ignition temperature of the gases, vapors and dusts for which the area in which they will be used is classified.

The valves in group II can also be used for less limiting temperature classes (surface temperature allowed higher).

		temperature range	N and V seals	NL seals	Temperature class	eligible also for
ATEX II 2G ATEX II 2D	*KD2	of ambient	-20 / +80 °C	-40 / +80 °C	T4 (gas)	T3, T2, T1
		of fluid			T154°C (dusts)	T200°C and higher
	*KD2 /T5	of ambient	-20 / +55 °C	-40 / +55 °C	T5 (gas)	T4, T3, T2, T1
		of fluid	-20 / +60 °C	-40 / +60 °C	T129°C (dusts)	T135°C and higher
ATEX I M2	*KDM2	of ambient	-20 / +75 °C	-40 / +75 °C	T150°C	-
		of fluid				



2 - IECEX CLASSIFICATION AND TEMPERATURES

The IECEX certification requires the classification of the electrical equipment only.

Diplomatic supplies valves with IECEX certified coils, suitable for application and installation in potentially explosive atmospheres. The mechanical construction of the coil housing is made in order to ensure its resistance to possible internal explosion and to avoid any explosion propagation to the outside environment, matching an "Ex db" type protection (explosion-proof coil).

Moreover, the solenoid is designed to maintain its surface temperature below the limits specified to the relevant class.

The supply always includes the operating and maintenance manual, that contains all the information needed for a correct use of the valve in potentially explosive environment.

2.1 - IECEX classification

Certificate of conformity (CoC): IECEX TUN 15.0028X

The valves are suitable for applications and installations in potentially explosive atmospheres that fall within:

IECEX Gb IECEX Db	*KXD2	equipment intended for use in areas in which explosive atmospheres caused by gases, vapours, mists or air/dust mixtures are likely to occur occasionally. The means of protection relating to equipment in this category ensure the requisite level of protection, even in the event of frequently occurring disturbances or equipment faults which normally have to be taken into account.
IECEX Mb	*KXDM2	equipment intended for use in underground parts of mines as well as those parts of surface installations of such mines likely to be endangered by firedamp and/or combustible dust. This equipment is intended to be de-energised in the event of an explosive atmosphere.

2.2 - IECEX marking

There is a plate with the IECEX mark on each coil.

*KXD2 valves	for gas	Ex db IIC T4 Gb (-40°C Ta +80°C)
	for dusts	Ex tb IIIC T135°C Db (-40°C Ta +80°C)
*KXD2 /T5 valves	for gas	Ex db IIC T5 Gb (-40°C Ta +55°C)
	for dusts	Ex tb IIIC T100°C Db (-40°C Ta +55°C)
*KDM2 valves	mining	Ex db I Mb (-40°C Ta +80°C)

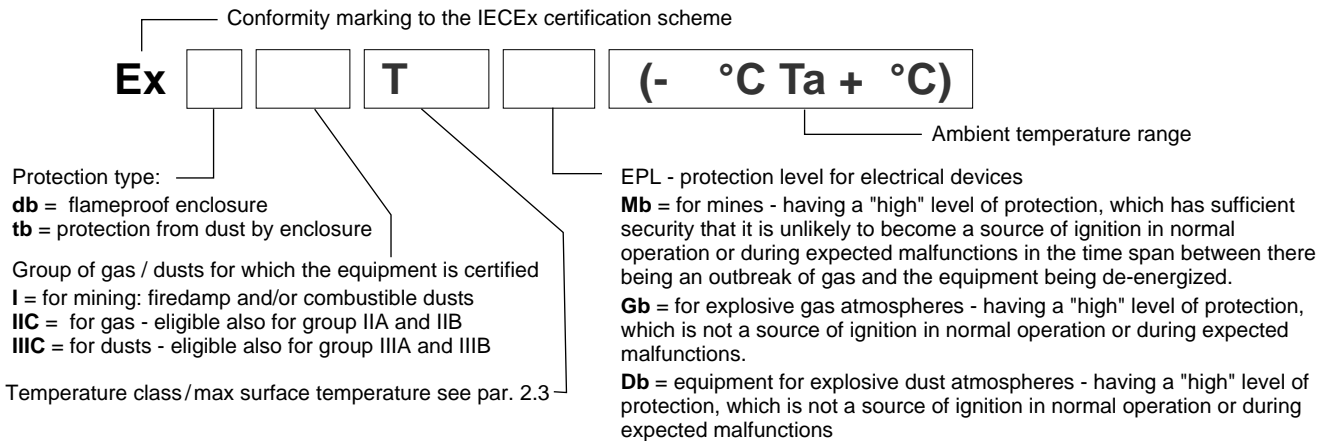

2.3 - Operating temperatures

These valves are classified according to their maximum surface temperature (EN 13463-1), which must be lower than the ignition temperature of the gases, vapors and dusts for which the area in which they will be used is classified.

Valves for surface plants can also be used for less limiting temperature classes (higher surface temperature allowed).

		temperature range	N and V seals	NL seals	Temperature class	eligible also for
IECEX Gb IECEX Db	*KXD2	of ambient	-20 / +80 °C	-40 / +80 °C	T4 (gas) T135°C (dusts)	T3, T2, T1 T200°C and higher
		of fluid				
IECEX Gb IECEX Db	*KXD2 /T5	of ambient	-20 / +55 °C	-40 / +55 °C	T5 (gas) T100°C (dusts)	T4, T3, T2, T1 T135°C and higher
		of fluid				
IECEX Mb	*KXDM2	of ambient	-20 / +80 °C	-40 / +80 °C	-	-
		of fluid				

2.4 - Protection degree from atmospheric agents (IEC EN 60529)

Protection degree from atmospheric agents according to IEC EN 60529 is IP66/IP68.



3 - PESO CLASSIFICATION AND TEMPERATURES

The PESO certification requires the classification of the electrical equipment only.

Diplomatic supplies valves with PESO certified coils, suitable for application and installation in potentially explosive atmospheres. The mechanical construction of the coil housing is made in order to ensure its resistance to possible internal explosion and to avoid any explosion propagation to the outside environment, matching an "Ex db" type protection (explosion-proof coil).

Moreover, the solenoid is designed to maintain its surface temperature below the limits specified to the relevant class.

The supply always includes the operating and maintenance manual, that contains all the information needed for a correct use of the valve in potentially explosive environment.

3.1 - PESO classification

Certificate of conformity: P480801

The valves are suitable for applications and installations in potentially explosive atmospheres that fall within:

PESO Gb	*KPD2	equipment intended for use in areas in which explosive atmospheres caused by gases, vapours, mists are likely to occur occasionally. The means of protection relating to equipment in this category ensure the requisite level of protection, even in the event of frequently occurring disturbances or equipment faults which normally have to be taken into account.
---------	--------------	--

3.2 - PESO marking

There is a plate with the PESO mark on each coil.

*KPD2 valves	for gas	Ex db IIC T4 Gb (-40°C Ta +80°C)
*KPD2 /T5 valves	for gas	Ex db IIC T5 Gb (-40°C Ta +55°C)

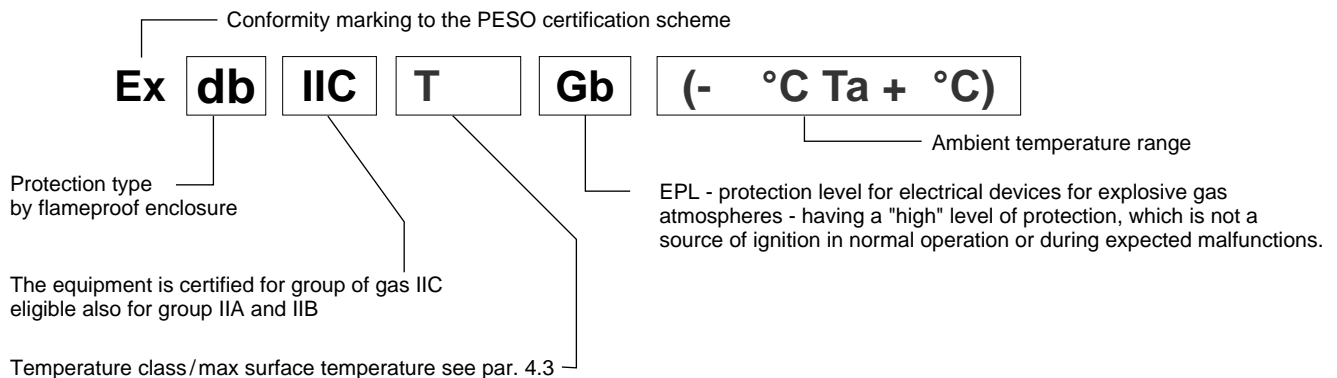

3.3 - Operating temperatures

These valves are classified according to their maximum surface temperature (EN 13463-1), which must be lower than the ignition temperature of the gases, vapors and dusts for which the area in which they will be used is classified.

Valves for surface plants can also be used for less limiting temperature classes (higher surface temperature allowed).

		temperature range	N and V seals	NL seals	Temperature class	eligible also for
PESO Gb	*KPD2	of ambient	-20 / +80 °C	-40 / +80 °C	T4 (gas)	T3, T2, T1
		of fluid				
	*KPD2 /T5	of ambient	-20 / +55 °C	-40 / +55 °C	T5 (gas)	T4, T3, T2, T1
		of fluid	-20 / +60 °C	-40 / +60 °C		

3.4 - Protection degree from atmospheric agents (IEC EN 60529)

Protection degree from atmospheric agents according to IEC EN 60529 is IP66/IP68.



DUPLOMATIC
MOTION SOLUTIONS
*a member of **DAIKIN** group*

DUPLOMATIC MS Spa

via Mario Re Depaolini, 24 | 20015 Parabiago (MI) | Italy
T +39 0331 895111 | E vendite.ita@duplomatic.com | sales.exp@duplomatic.com
duplomaticmotionsolutions.com